

**new**

# C/E H SMART



## HAMBURGATRICE AUTOMATICA

- Struttura in acciaio inox e alluminio anodizzato.
- Rulli in Delrin® intercambiabili ad una o due forme.
- Nastro trasportatore di serie
- New!** Pala innesto rapido
- "Interleaver"; interfogliatore di carta (opzionale)
- Vetrina in acciaio inox e coperchio in metacrilato trasparente
- New!** Pulizia filo Manuale a macchina accesa e vetrina chiusa
- Materiali idonei al contatto con gli alimenti.
- Finecorsa magnetici di sicurezza codificati e protezioni fisiche per impedire l'accesso alle parti in movimento.
- Veloce smontaggio dei articolari a contatto col macinato (vasca, pala, rullo formatore)
- Parti elettriche in scatola con protezione IP 55.

## AUTOMATIC PATTY FORMER

- Structure in stainless steel and anodized aluminium
- Exchangeable cylinder made in Delrin®, one or two shapes
- Standard conveyor belt
- New!** Fast coupling paddle
- Paper interleaver (optional)
- Transparent methacrylate lid and stainless steel frontal window
- New!** Manual wire cleaning while the machine is in operation and with locked frontal window
- Certified materials for food contact
- Codified magnetic micro-switches and safety guards to prevent access to moving parts
- Paddles, forming cylinder and product feed hopper easily removable for cleaning and maintaining
- Electric parts into IP55 box



## RECONSTITUEUR AUTOMATIQUE

- Structure en acier inox et aluminium anodisé
- Rouleaux reconstituer interchangeables en Delrin®, une ou deux formes
- Ruban transporteur standard
- Nouveau!** Pelle avec attache rapide
- "Interleaver"; distributeur automatique de papier (optionnel)
- Vitrine et couvercle transparents en méthacrylate (les deux avec verrouillage rapide)
- Nouveau!** Nettoyage du fil manuel, pendant que la machine est en fonction et avec le vitre frontale verrouillée
- Composantes homologuées pour usage alimentaire
- Fins de course de sécurité magnétiques codifiées et protections pour interdire l'accès à toutes les pièces qui bougent
- Bac, pales et rouleau reconstituer sont faciles à démonter pour le nettoyage et l'entretien
- Composants électriques sous protection IP55

## MÁQUINA DE HAMBURGUESA

- Estructura en acero inox y aluminio anodizado
- Cilindros intercambiables en Delrin® (formas simples o dobles)
- Cinta transportadora de serie
- Nuevo!** Paleta con montaje rápido
- "Interleaver"; colocador de papel (opcional)
- Vitrina frontal y tapa superior en metacrilato transparente ambos con cierre rápido
- Nuevo!** Limpieza hilo manual con máquina funcionando y vitrina frontal cerrada
- Materiales idóneos al contacto con alimentos
- Sensores de seguridad magnéticos/codificados y protecciones físicas para impedir acceso a partes en movimiento
- Partes en contacto con la carne de simple/rápido desmontaje (cuba, paleta, cilindro)
- Partes eléctricas en caja con protección IP 55

### CARATTERISTICHE TECNICHE - TECHNICAL SPECIFICATIONS - TECHNISCHE DATEN - CARACTÉRISTIQUES - ESPECIFICACIONES

		C/E H SMART
Capacità tramoggia - Feed pan capacity - Contenance trémie - Trichterinhalt - Capacidad tolva	l	18
Produttività - Productivity - Production - Leistung - Productividad	pcs/h	1.000
Motore trifase - Threephase motor - Moteur triphasé - Dreiphasigmotor - Motor trifasico	kW (HP)	0,3 (0,4)
Motore monofase - Singlephase motor - Moteur monophasé - Einphasigmotor - Motor monofasico	kW (HP)	0,3 (0,4)
Forma - Shape - Moule Form - Forma	Ø mm	Hamburger Ø 50 a 120 mm  Cylindrical Meatball 2 x Ø 28 a 45 mm 
Peso netto - Net weight - Poids net - Nettogewicht - Peso neto	kg	48

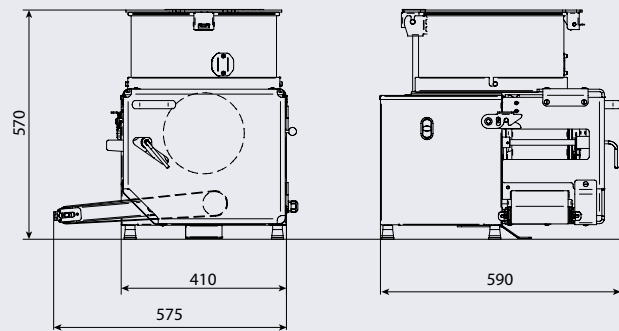

Macchina conforme alle norme CE in materia di igiene e di sicurezza.

The machine complies with CE standards in terms of hygiene and safety.

Interfogliatore - Interleaver



Pala innesto rapido - Fast coupling paddle



Pulizia filo a macchina accesa - Wire cleaning with machine on

